

Troubleshooting Chart:

Problem	Cause	Solution
1. No discharge	a. No water b. Magnetic valve not functioning c. Excessive water pressure d. Eductor clogged	a. Open water supply b. Install valve parts kit c. Install regulator if water pressure exceeds 60 PSI (flowing) d. Clean* or replace
2. No concentrate draw	a. Clogged foot valve b. Metering tip or eductor has scale build-up c. Low water pressure d. Discharge tube(s) not in place or flooding ring missing from inner discharge tube e. Concentrate container empty f. Inlet hose barb not screwed into eductor tightly g. Clogged water inlet strainer h. Selector out of position	a. Clean or replace b. Clean (descale)* or replace c. Minimum 20 PSI (with water running) required to operate unit properly d. Push tube firmly onto eductor discharge hose barb; be sure inner discharge tube is installed and has flooding ring. e. Replace with full container f. Tighten, but do not overtighten g. Disconnect inlet water line and clean strainer h. Assure selector is in position desired
3. Excess concentrate draw	a. Metering tip not in place b. Chemical above eductor	a. Press correct tip firmly into barb on eductor b. Place concentrate below the eductor
4. Failure of unit to turn off	a. Water valve parts dirty or defective b. Magnet doesn't fully return c. Push button stuck	a. Clean* or replace with valve parts kit b. Make sure magnet moves freely. c. Remove button and clean cabinet/button to remove any dirt lodged in slide recess
5. Excess foaming in discharge	a. Air leak in pick-up tube b. Inner discharge tube not in place	a. Put clamp on tube or replace tube if brittle b. Install inner discharge tube
6. Water discharge from air vents on eductor	a. Restricted discharge hose b. High water pressure	a. Be sure discharge tube is not immersed, kinked or elevated. Be sure there is no liquid in the discharge tube when beginning to operate dispenser b. Install pressure regulator if flowing water pressure exceeds 60 PSI (flowing)

*In hard water areas, scale may form inside the discharge end of the eductor, as well as in other areas of the unit that are exposed to water. This scale may be removed by soaking the eductor in a descaling solution (deliming solution). To remove an eductor located in the cabinet, firmly grasp water valve and unthread eductor. Replace in same manner. Alternatively, a scaled eductor can be cleaned (or kept from scaling) by drawing the descaling solution through the unit. Operate the unit with the suction tube in the descaling solution. Operate the unit until solution is drawn consistently, then flush the unit by drawing clear water through it for a minute. Replace concentrate container and put suction tube into concentrate.

Hydro® AccuDose Series Proportioner Model 3876AG-2 with HydroGap™ Air Gap Eductors

THANK YOU FOR YOUR INTEREST IN OUR PRODUCTS

Please use this equipment carefully and observe all warnings and cautions.

*****NOTE*****

- WEAR** protective clothing and eyewear when dispensing chemicals or other materials.
- ALWAYS** observe safety and handling instructions of the chemical manufacturers.
- ALWAYS** direct discharge away from you or other persons or into approved containers.
- ALWAYS** dispense cleaners and chemicals in accordance with manufacturer's instructions. Exercise CAUTION when maintaining your equipment.
- KEEP** equipment clean to maintain proper operation.
- WEAR** protective clothing and eyewear when working in the vicinity of all chemicals, filling or emptying equipment or changing metering tips.
- ALWAYS** re-assemble equipment according to instruction procedures. Be sure all components are firmly screwed or latched into position.
- ATTACH** only to tap water outlets (85 PSI maximum).

Package Should Contain:

1. Proportioner unit.
2. Supply tubing : 21' total.
3. Foot valve assemblies & weights (5).
4. Discharge tube for each eductor.
5. Metering tip kits.
6. Mounting anchor kit.
7. Hook for 3.5 GPM discharge tube.
8. Instruction sheet.

Installation and Operation:

1. Remove cabinet cover. Install the short, whitish inner discharge tubes on the outlets of the eductors. They go over the smaller barbed parts on the bottoms of the eductors. These tubes must be in place for the eductors to function. The inner discharge tube for the 3.5 GPM (yellow) eductor has a yellow flooding ring inside it. The inner discharge tube for the 1.0 GPM (grey) eductor has a grey flooding ring inside it. Install the end of the tube nearest the flooding ring on the eductor's inner discharge barb. **To ensure the IDTs are on correctly, see that the metal rings get positioned above the small barbs.**
2. Drill holes for the three wall anchors with a 5/16" drill bit, using the cabinet back as a template for proper spacing of the mounting screws. Install mounting anchors, and then screws in top two anchors. Slide key holes in cabinet back over screw heads, tighten screws, then install bottom screw. Do not mount more than 6 feet (1.8 meters) above the bottom of the concentrate container, nor below the highest concentrate level (never mount your concentrate higher than the proportioner).
3. Select metering tips (up to 4) for the selector valve (see next two sections). Push each tip firmly into a separate hose barb extending from the selector valve. A tip with no hole (clear plastic color) can be used to block any valve port not being used. (This may be used for dispensing water only.) Select and install a metering tip for the single product eductor (right side) in the same manner.
4. Cut tubing provided into separate supply tubes for each product to be dispensed (tubing allows for 7 feet of tube per product). Supply tubes should reach from hose barbs on the selector valve body and eductor to bottom of concentrate containers. Slide ceramic weights over one end of each tube and slide foot valves into the same ends of the tubes.
5. Slip open end of each supply tube through an opening in either side of the cabinet and push over a hose barb/metering tip on the selector valve and on the eductor.
6. Place foot valve ends of supply tubes into concentrate containers. **REMEMBER TO CHECK FOOT VALVE STRAINERS PERIODICALLY FOR CLOGGING: CLEAN IF NECESSARY.**
7. A short discharge tube is used with the 1 GPM eductor (selector valve); minimum tube length is 8 inches (20 cm) for proper operation. A longer tube (4 feet) is used with the 3.5 GPM eductor. Slide end of tube over inner discharge tube and onto eductor discharge outlet. The hose hook supplied may be installed on the long tube to allow it to conveniently hang from dispenser when not in use.
8. Replace cabinet cover. Push the sides in, behind the latch holes, to snap the cover in place. The two screws provided may be installed in the holes in the cabinet sides to prevent easy removal of cover.
9. Connect water supply hose of at least 3/8" ID to water inlet swivel. (Minimum 20 PSI pressure, with water running, is required for correct operation.) Connect opposite end of hose to water supply. Turn water supply on.
10. Purge air from the system by depressing the buttons briefly. There may be some water discharge from the eductor vents until the air is purged.
11. Push button to start flow of desired water/concentrate solution, and hold until supply tube is primed (filled). Then push the button whenever dispensing is desired, and release button to stop flow of solution. **If you wish to be able to lock the button in the "on" position:** Clip or bend the two tabs behind the lower front portion of the button. (Seediagram at right.) This allows the button to be fully depressed and allows it to latch in the "on" position. **To unlock, pull the button out.**
12. **It is essential that the discharge hose not be obstructed. If discharge is restricted, water will flow out the eductor vents. Do not start to operate the dispenser with liquid in the discharge tube.**

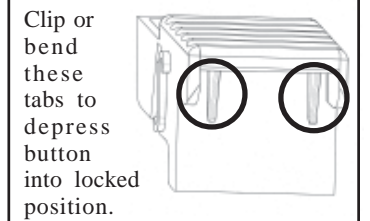

Metering Tip Selection:

The final concentration of the dispensed solution is related to both the size of the metering tip opening and the viscosity of the liquid being siphoned. For water-thin products, the chart at left can be used as a guideline. If product is noticeably thicker than water, consult the Measurement of Concentration Procedure below to achieve your desired water-to-product ratio. Because dilution can vary with water temperature and pressure, actual dilution achieved can only be ascertained by using the Measurement of Concentration Procedure. The clear, undrilled tip is provided to permit drilling to size not listed should you need a dilution ratio that falls between standard tip sizes.

NOTE: A 1 GPM eductor is grey; a 3.5 GPM eductor is yellow. Refer to parts diagram if unfamiliar with names of system components.

Measurement of Concentration:

You can determine the dispensed water-to-product ratio for any metering tip size and product viscosity. All that is required is to operate the primed dispenser for a minute or so and note two things: the amount of dispensed solution, and the amount of concentrate used in preparation of the solution dispensed. The water-to-product ratio is then calculated as follows:

$$\text{Dilution Ratio (X:1) where X} = \frac{\text{Amount of Mixed Solution} - \text{Amount of Concentrate Drawn}}{\text{Amount of Concentrate Drawn}}$$

Dilution Ratio, then, equals X parts water to one part concentrate (X:1). If the test does not yield the desired ratio, choose a different tip and repeat the test. Alternative methods to this test are 1) pH (using litmus paper), and 2) titration. Contact your concentrate supplier for further information on these alternative methods and the materials required to perform them.

APPROXIMATE DILUTIONS AT 40 PSI FOR WATER-THIN PRODUCTS (1.0 CP)				
Tip Color	Orifice Size	Std. Drill Number	Ratio (per Eductor Flow)	
			1 GPM	3.5 GPM
No Tip	.187	(3/16)	3:1	3.5:1
Grey	.128	(30)	3:1	4:1
Black	.098	(40)	3:1	4:1
Beige	.070	(50)	4:1	8:1
Red	.052	(55)	5:1	14:1
White	.043	(57)	7:1	20:1
Blue	.040	(60)	8:1	24:1
Tan	.035	(65)	10:1	30:1
Green	.028	(70)	16:1	45:1
Orange	.025	(72)	20:1	56:1
Brown	.023	(74)	24:1	64:1
Yellow	.020	(76)	32:1	90:1
Aqua	.018	(77)	38:1	128:1
Purple	.014	(79)	64:1	180:1
Pink	.010	(87)	128:1	350:1

AccuDose Parts Diagram:

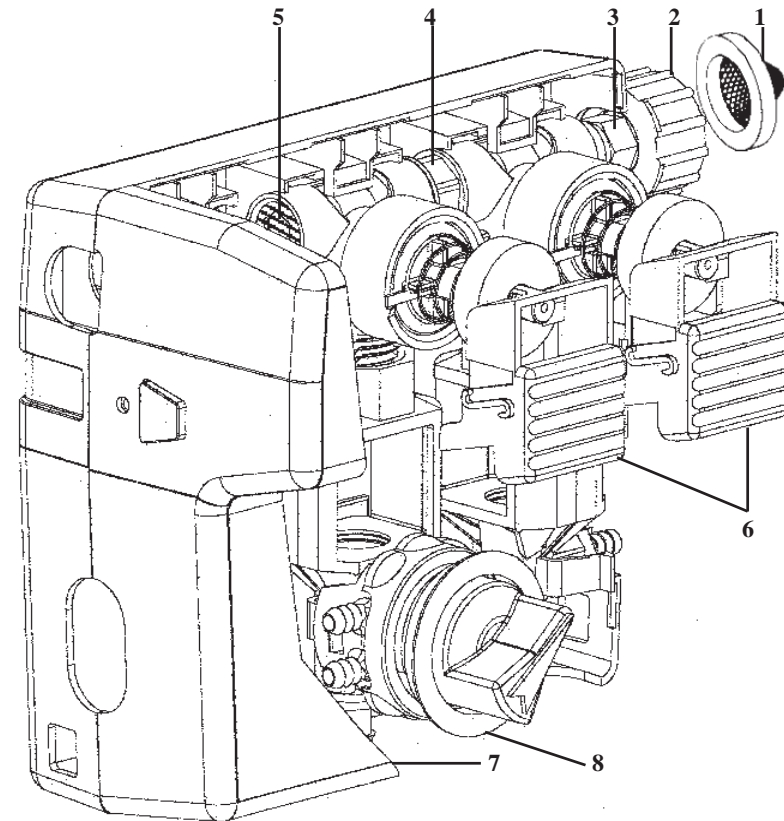

Key	Part No.	Description
1	238100	Strainer washer
2	10082830	Swivel collar (molded)
3	10082801	Swivel stem (molded)
4	10075911	Hex nipple
	10075950	O-ring (two per nipple)
5	10075925	Pipe plug
6	10080710	Button, dark grey (standard)
	10080711	Button, sky blue
	10080712	Button, red
	10080713	Button, green
	10080714	Button, light grey
	10080715	Button, yellow
7	10080895	Cabinet
8	10020700	Selector valve grommet
	10020900	Back up ring for grommet
9	10075980	Valve parts kit
		a. diaphragm, b. armature, c. spring, d. valve bonnet
10	10079010	Spring
11	10079000	Magnet
12 a	160	1 GPM Eductor assembly
	b 161	3.5 GPM Eductor assembly
	c 3401-R	Eductor hose barb only
13 a	10070170	1 GPM inner discharge tube
	b 10070470	3.5 GPM inner discharge tube
14 a	10064794	1 GPM outer discharge tube (7")
	b 10077310	3.5 GPM outer discharge tube (4")

AccuDose Parts Diagram/List:

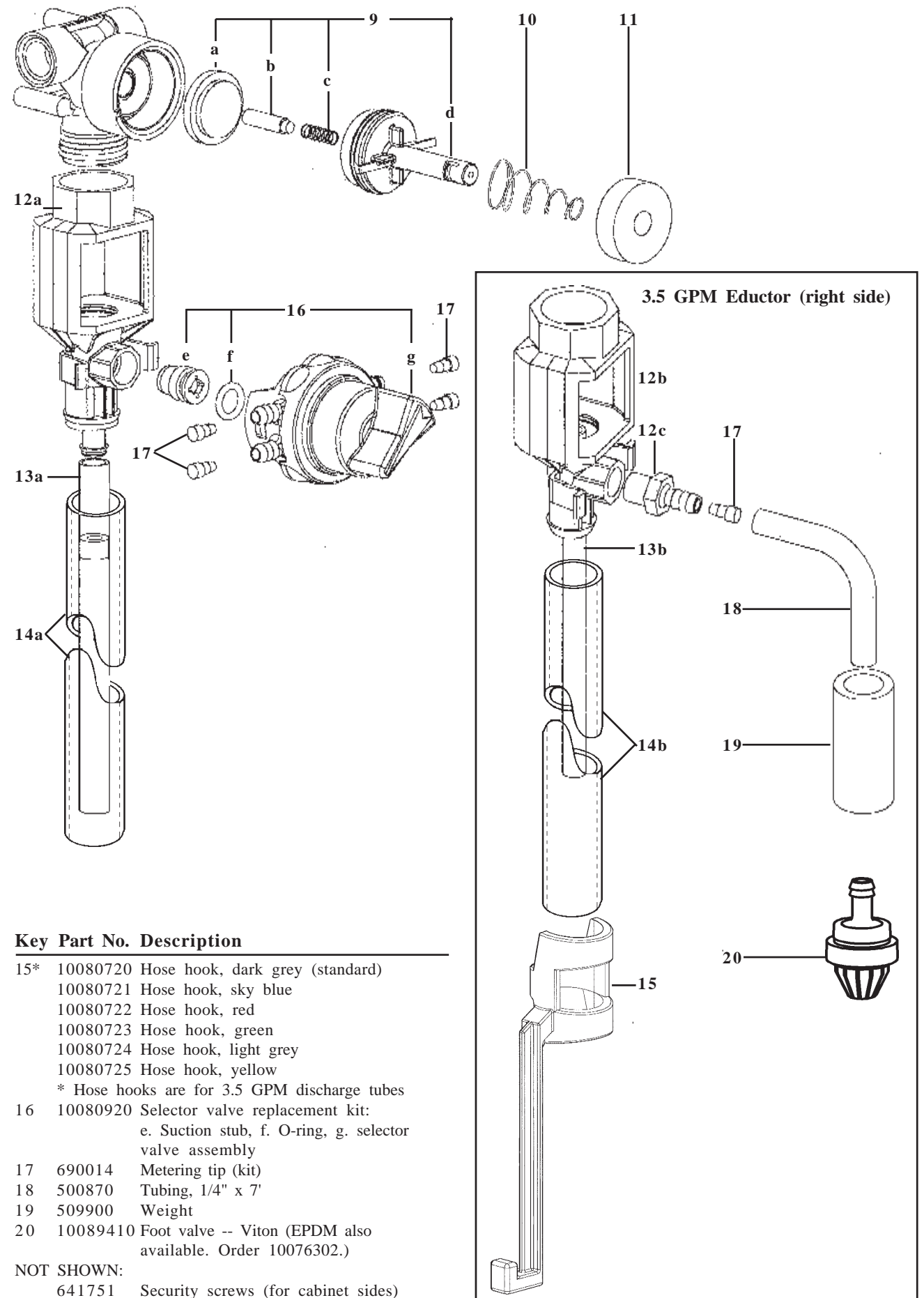

Key	Part No.	Description
15*	10080720	Hose hook, dark grey (standard)
	10080721	Hose hook, sky blue
	10080722	Hose hook, red
	10080723	Hose hook, green
	10080724	Hose hook, light grey
	10080725	Hose hook, yellow
	* Hose hooks are for 3.5 GPM discharge tubes	
16	10080920	Selector valve replacement kit:
		e. Suction stub, f. O-ring, g. selector valve assembly
17	690014	Metering tip (kit)
18	500870	Tubing, 1/4" x 7'
19	509900	Weight
20	10089410	Foot valve -- Viton (EPDM also available. Order 10076302.)

NOT SHOWN:
641751 Security screws (for cabinet sides)